



Kvaser Memorator 2xHS v2 User's Guide



Copyright 2016–2026 Kvaser AB, Mölndal, Sweden
<https://www.kvaser.com>

Printed Wednesday 18th February, 2026

We believe that the information contained herein was accurate in all respects at the time of printing. Kvaser AB cannot, however, assume any responsibility for errors or omissions in this text. Also note that the information in this document is subject to change without notice and should not be construed as a commitment by Kvaser AB.

(This page is intentionally left blank.)

Contents

1	About this manual	4
2	Introduction	5
2.1	Welcome to Kvaser Memorator 2xHS v2	5
2.2	Major features	6
2.3	Interface and logger	6
2.4	Configuration software in the host computer	7
2.5	Additional software and documentation	7
3	Kvaser Memorator 2xHS v2 hardware	8
3.1	Hardware installation	8
3.2	USB connector	8
3.3	CAN channels	9
3.4	Power supply	9
3.5	SD Card	10
3.6	LED Indicators	11
3.7	Troubleshooting	11
4	Appendices	13
4.1	Definitions of LED states and colors	13
4.2	Technical data	16
4.3	CAN connectors	16
4.4	CAN bus termination	17
4.5	External trigger input	17
4.6	External trigger output	19
4.7	Daisy Chain Several Devices	19
4.8	Updating the firmware	20
5	Safety Instructions	21
5.1	Intended Use	21
5.2	Usage Warning	21
6	Disposal and Recycling Information	22
7	Legal acknowledgements	24
7.1	EU Regulatory Compliance	24
7.2	FCC Regulatory Compliance	25
7.3	Patents, Copyrights and Trademarks	26
8	Document Revision History	27

1 About this manual

This manual is intended for Kvaser Memorator 2xHS v2 users. This document contains a description of the hardware's properties and general instructions for connecting the device to a computer.

2 Introduction

This section will describe the functions and features of the Kvaser Memorator 2xHS v2.



You must charge the battery before using your Kvaser Memorator 2xHS v2 for the first time. See Section 3.4, Power supply, on Page 9 for more information.

2.1 Welcome to Kvaser Memorator 2xHS v2



Figure 1: Kvaser Memorator 2xHS v2

Kvaser Memorator 2xHS v2 is a small, yet advanced, portable CAN data logger that handles transmission and reception of standard and extended CAN messages on the bus with a high time stamp precision. Kvaser Memorator 2xHS v2 can also be used as a powerful real time CAN to USB interface. It is compatible with applications that use Kvaser's CANlib.

This guide applies to Kvaser Memorator 2xHS v2 devices listed in Table 1.

Device	Product Number (EAN)	Firmware
Kvaser Memorator 2xHS v2	73-30130-00821-2	v3.3

Table 1: Kvaser Memorator 2xHS v2 devices and their product numbers.

2.2 Major features

- Data logger
- USB CAN interface.
- Quick and easy plug-and-play installation.
- Supports both 11-bit (CAN 2.0A) and 29-bit (CAN 2.0B active) identifiers.
- 100% compatible with applications written for other Kvaser CAN hardware with Kvaser CANlib.
- High-speed CAN connection (compliant with ISO 11898-2), up to 1 Mbit/s.
- Fully compatible with J1939, CANopen, NMEA 2000[®] and DeviceNet.
- Supports silent mode for analysis tools – listen to the bus without interfering.
- Supports simultaneous usage of multiple Kvaser interfaces.
- One SD card slot for logging.
- Logger status is indicated with externally visible LEDs.

2.3 Interface and logger

Kvaser Memorator 2xHS v2 provides a CAN bus interface through a standard USB interface or logs data from a CAN bus to a standard SD card. The device is in Interface mode when connected to the host computer via USB, and in Logger mode when only connected to CAN power.

Kvaser Memorator 2xHS v2 can log continuously, or logging can be triggered by external triggers (rising or falling edge) and/or by messages on the CAN bus (triggered by identifier, data contents or error frames.) Pre- and post-trigger times can be set.

To enhance logging performance, Kvaser Memorator 2xHS v2 can filter out messages to be logged. The identifiers can be picked from a database file, or all messages can be logged.

2.3.1 Triggers

Triggers are useful if you want the Kvaser Memorator 2xHS v2 to start logging when something special happens. An example of a trigger is a specific incoming CAN message.

The triggers are combined using logical operators into expressions. More than one trigger may be used in an expression.

An action is then associated with the expression, where the action describes what should happen when the expression is true, e.g. start logging.

Kvaser Memorator 2xHS v2 supports two expressions and may associate one single action to each expression.

2.4 Configuration software in the host computer

To be able to configure Kvaser Memorator 2xHS v2, you need to install Kvaser Memorator Config Tool which can be downloaded at www.kvaser.com/download. The Kvaser Memorator Config Tool will assist in:

- Configuration of the CAN controller (e.g. bit rate and filters).
- Configuration of the trigger conditions (including up to 32 bit signals from databases).
- Configuration of message filters.
- Downloading configuration via USB or SD card reader.
- Extracting logged messages via USB or SD card.
- Converting files logged in Kvaser Memorator 2xHS v2 to several different formats.

For a detailed description, and how to get started, see the on-line help available inside Kvaser Memorator Config Tool.

2.5 Additional software and documentation

The Kvaser CANlib SDK includes everything you need in order to develop software applications interacting with Kvaser CAN and LIN hardware. The SDK contains full documentation and many sample programs, written in C, C++, C#, Delphi, Python and Visual Basic. Kvaser CAN and LIN hardware is built around the same common software API. Applications developed using one device type will run without modification on other device types.

The latest versions of documentation, software and drivers can be downloaded for free at www.kvaser.com/download.

3 Kvaser Memorator 2xHS v2 hardware

In this section you can read more about the CAN channels, power supply and LED indicators.

3.1 Hardware installation

For the Kvaser Memorator 2xHS v2 to communicate with the host computer, a compatible version of the Kvaser driver and firmware must be installed.

After the driver has been installed on the host computer, the firmware may then be downloaded and installed on the Kvaser Memorator 2xHS v2.

The latest version of the driver and firmware can be downloaded from www.kvaser.com/download.

The driver is installed by running the file `kvaser_drivers_setup.exe`.

The Kvaser Memorator 2xHS v2 may be inserted in any free USB socket on the host computer. You do not need to switch the power off before inserting or removing the device.

For information on how to upgrade the firmware, see Section 4.8, Updating the firmware, on Page 20.

3.2 USB connector

The Kvaser Memorator 2xHS v2 has a standard USB type "Micro-B" female connector.



Figure 2: Micro USB cable connected to the Kvaser Memorator 2xHS v2.

Connect the device to your computer using any high quality USB 2.0 certified cable. The maximum total USB cable length is 5 m (~ 16 ft).



As USB cables become longer they are more sensitive to EMI, because they make a longer antenna that can pick up more noise. These issues can be mitigated by using higher quality cables with better shielding. Thicker cables tend to be better than thin ones, and braided shielding tends to be more reliable than only foil. Furthermore, longer cables may introduce signal degradation and timing issues that, if necessary, can be mitigated using shorter cable segments combined with hubs that amplify the signal and handle delays on a per-cable basis.

3.3 CAN channels

The Kvaser Memorator 2xHS v2 has two CAN Hi-Speed channels with separate 9-pin D-SUB CAN connectors (see Figure 3). See Section 4.3, CAN connectors, on Page 16 for pinout information.



Figure 3: CAN connector on Kvaser Memorator 2xHS v2

3.4 Power supply

The Kvaser Memorator 2xHS v2 can be powered through the CAN 1 connector or through the USB connector.

To operate the Kvaser Memorator 2xHS v2 in logger mode, you **must** supply power through the CAN 1 connector. To use the device as a USB CAN interface or to configure the device, power on the USB side is sufficient.

The Kvaser Memorator 2xHS v2 contains a battery that needs to be fully charged before using the device for the first time. Connect the Kvaser Memorator 2xHS v2 to either a powered USB port or supply power through the CAN connector and let the battery charge overnight.

The battery inside the Kvaser Memorator 2xHS v2 is used for powering the real time clock and ensuring a safe shutdown of the device when disconnected. When

in logger mode, the Kvaser Memorator 2xHS v2 can also use the battery to extend the logging time by a number of seconds (accessible from the Power Settings in Kvaser Memorator Config Tool).

To maintain a healthy battery you need to:

- Always connect the Kvaser Memorator 2xHS v2 to a properly powered USB hub, using the supplied cable, when connected to a computer.
- When using the feature to extend time to live after CAN power is disconnected, always make sure to recharge the device between each use. To fully recharge the device, connect to power for up to 20x “live time” (e.g. 15s battery use might require up to 5 min of recharging).
- If the Kvaser Memorator 2xHS v2 is not used regularly, ensure the device is recharged at least twice a year overnight at room temperature.



All charging times are given at temperatures between -10°C to $+40^{\circ}\text{C}$. In warmer and colder temperatures the charging time will increase.

See Section 4.3, CAN connectors, on Page 16 for information on how to connect power to the connector. The supply power should be in the range specified in Section 4.2, Technical data, on Page 16.

3.5 SD Card

You can use SD, and SDHC cards up to a size of 512GB with your Kvaser Memorator 2xHS v2 for logging. The Kvaser Memorator 2xHS v2 is built with industrial environments in mind, but please note that the SD card used can be a limiting factor. By using a quality card that matches the specifications of the Kvaser unit, you minimize the risk for data corruption or lost data.

Insert the SD card upside down into your Kvaser Memorator 2xHS v2 (see Figure 4 on Page 11). Do not apply excessive force.

To remove the SD card, open the access door and using a finger or a small coin, gently press on the edge of the SD card until a click is heard. Release the card and it will partially eject. Remove the SD card completely.



The setting of the write protection switch on SD cards is disregarded by design. The Kvaser Memorator 2xHS v2 will write to the disk even if the write protection switch is set.



Figure 4: Inserting SD card into the Kvaser Memorator 2xHS v2.

3.6 LED Indicators

The Kvaser Memorator 2xHS v2 has one power LED and one traffic LED for each CAN channel as shown in Figure 5. Their functions are described in Section 4.1, Definitions of LED states and colors, on Page 13.

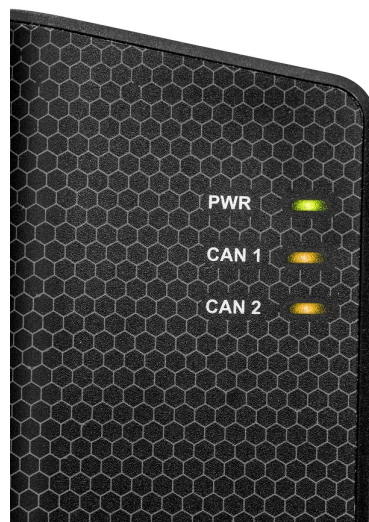

Figure 5: LEDs on the Kvaser Memorator 2xHS v2.

3.7 Troubleshooting

Use “Kvaser Device Guide” in the Control Panel to verify that the computer can communicate with the Kvaser Memorator 2xHS v2. If the firmware version shown

is all zeros, there are communication problems. If the LEDs are not flashing or do not light up at all, check the power supply. If the battery has been depleted, no LEDs will light up. Connect the Kvaser Memorator 2xHS v2 to either a properly powered USB port or supply power through the CAN connector and let the battery charge overnight.

4 Appendices

In this section you will find technical information about the Kvaser Memorator 2xHS v2 and its connectors.

4.1 Definitions of LED states and colors

A Kvaser device has two basic types of LEDs; Power and Traffic. These are dual colored as shown in Table 2. A device with multiple CAN channels has one Traffic LED for each CAN channel. When the device has more than one channel a space and digit is added on the label, CAN 1, CAN 2 etc. The red Traffic LEDs are also used to indicate errors by using all red Traffic LEDs simultaneously.

LED	Label	Color
Power	PWR	Green/Yellow
Traffic	CAN	Yellow/Red

Table 2: The different type of LEDs.

The following definitions are used to describe the state of an LED:

Off The LED is off and no light is emitted.

Flash The LED is lit up for a very short time. A single flash may be hard to see and a continuous set of flashes will look the same as On.

Slow Blink The LED is repeatedly turned On and Off. The On and Off phase is equal in time.

Fast Blink The LED is repeatedly turned On and Off but with a higher frequency than Slow Blink. The On and Off time is still equal.

On The LED is constantly emitting light.

Slow Waver This is a variant of Slow Blink but instead of being Off, a second color is On. This is only possible with a dual colored LED.

Fast Waver The LED is alternating between two colors as in Slow Waver but using a higher frequency.

Running This means that all LEDs are lit, one at the time, in sequence with every color available i.e. "Power green->Power yellow->Traffic 1 yellow->Traffic 1 red->Traffic 2 yellow->Traffic 2 red->..."

As an example, "Slow Waver (Green/Yellow)" means that the LED is slowly blinking by alternating between green and yellow.

4.1.1 Interface mode

The device is in Interface mode when connected to the host computer via USB. If the Power LED is showing a steady green light, the device is in Interface mode and working correctly. When connected to the computer for the first time, the Power LED will blink slowly in yellow until the driver is installed and the device has received a USB configuration.

When in Interface mode, if the Power LED is yellow for an extended period, something is wrong. Please see Table 3.

When the device is connected to Kvaser Memorator Configuration Tool (in Interface mode), the LED will be showing any of the states shown in Table 5.



The power should never be removed during disk activity or when firmware update is in progress.

Power LED	Traffic LED	Description
Slow Blink (Yellow)	All off (-)	Waiting for USB configuration
Slow Waver (Green/Yellow)	Slow Waver (Yellow/Red)	Firmware configuration error ¹
Slow Waver (Green/Yellow)	All Slow Blink (Yellow)	Power problem ²

Table 3: Yellow Power LED shows problems in Interface mode.

Traffic LED	Description
Off (-)	Idle, no CAN traffic
Flash (Yellow)	CAN message received or sent
Flash (Red)	Error frame received
All Fast Blink (Yellow)	Firmware update is in progress
Fast Blink (Red)	CAN channel is error passive
On (Red) ³	CAN overrun

Table 4: Traffic LED shows CAN bus status in Interface mode and Logger mode.

Power LED	Traffic LED	Description
Running	Running	Device is communicating with Memorator Tools
On (Green)	All Fast Blink (Yellow)	Disk activity such as formatting or firmware update is in progress

Table 5: LED indications when connected to Kvaser Memorator Configuration Tools.

¹This should not normally happen. If it does, please contact Kvaser support.

²This indicates low power supply, such as using an unpowered USB hub.

³The red Traffic LED indicating overrun will stay on until the device goes bus off.

4.1.2 Logger mode

The device is in Logger mode when only connected to CAN power. If all the Traffic LEDs are showing the same pattern (most likely including red) there is some problem and the Power LED will indicate what type of problem according to Table 6 on Page 15.

When in operational mode, the green Power LED shows what state the device is in (armed, active or stopped), see Table 7, and the Traffic LEDs are showing the status of the CAN bus in the same way as in Interface mode, see Table 4 on Page 14.

Power LED	Traffic LED	Description
Fast Waver (Green/Yellow)	All Fast Waver (Yellow/Red)	Firmware or Hardware error ⁴
Fast Waver (Green/Yellow)	All Slow Waver (Yellow/Red)	Battery fault
Yellow On	All Slow Blink (Red)	Disk full or Disk error
Yellow On	All Fast Blink (Red)	Configuration file missing or corrupt ⁵

Table 6: When all Traffic LEDs are showing the same pattern, the Power LED indicates the problems in Logger mode.

Power LED	Description
On (Green)	Device Armed
Fast Blink (Green)	Logging active
Slow Blink (Green)	Logging stopped due to trigger

Table 7: The green Power LED indicates that the device is in a valid state.

⁴This should not normally happen. If it does, please contact Kvaser support.

⁵This also includes the case where a t program failed to load and start as configured.

4.2 Technical data

In Table 8 below you will find the Kvaser Memorator 2xHS v2's technical specifications.

CAN Channels	2
CAN Transceivers	Compliant with ISO 11898-2
CAN Controller	Kvaser CAN IP in FPGA
Galvanic isolation	Yes
CAN Bit Rate	20 kbit/s to 1 Mbit/s
Time stamp resolution	100 μ s
Max message rate (interface)	8000 msg/s per channel
Max message rate (logging)	8000 msg/s per channel
Error Frame Detection	Yes
Error Frame Generation	No
Silent mode	Yes
Kvaser t programming	No
Kvaser CANtegrity	No
Host interface	USB Hi- and Full-Speed
Host OS	Windows (7 or later), Linux, Android.
External power	9–40 V
Power consumption	Up to 3W
Hardware configuration	Done by software (Plug & Play).
Dimensions	55 x 150 x 23 mm for body incl. strain relief
Weight	155 g
Operating temperature	–20 °C to +70 °C
Storage temperature	–40 °C to +85 °C
Relative humidity	0% to 85% (non-condensing.)

Table 8: Technical Specifications

>

4.3 CAN connectors

Kvaser Memorator 2xHS v2 devices that use the 9-pin D-SUB connector (see Figure 6 on Page 17) have the pinning described in Table 9 on Page 17.

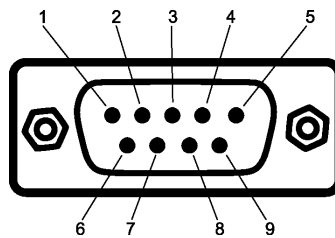

Figure 6: The D-SUB 9 connector pin numbers

D-SUB pin number	Function
1	Not connected
2	CAN_L
3	GND
4	External trigger (CAN 1: Trigger input, CAN 2: Trigger output)
5	Shield
6	Not connected
7	CAN_H
8	Not connected
9	Power supply to the device (CAN 1 only)

Table 9: Configuration of the 9-pin D-SUB

4.4 CAN bus termination

Every CAN bus must be terminated with a 120 Ohm resistor at each end of the bus. The Kvaser Memorator 2xHS v2 does not contain any CAN bus termination, because their inclusion could cause severe disturbance in a system which is already correctly terminated.

For laboratory or testing use, the exact value of the termination resistors is not always critical. Sometimes a single terminator is sufficient. For production, proper termination is essential. If you see error frames on the bus, you should check the termination.



To save yourself a lot of trouble, always terminate the CAN bus properly.

4.5 External trigger input

The Kvaser Memorator 2xHS v2 can be set up to trigger on an external signal and can be configured to react on both falling and rising edges.

- If it is set to trigger on a falling edge, the trigger is activated when the External trigger is connected to ground.
- If it is set to trigger on a rising edge, the trigger is activated when the External trigger is disconnected from ground.

There are two ways to create such an external signal, either connect a switch from the External trigger input on CAN channel 1 to ground or connect a signal between 0 and 5 V to the External trigger input. See Section 4.3, CAN connectors, on Page 16 for pin numbering.

The trigger input is debounced by the firmware so that a pulse of shorter length than approximately 30 ms will not be detected.

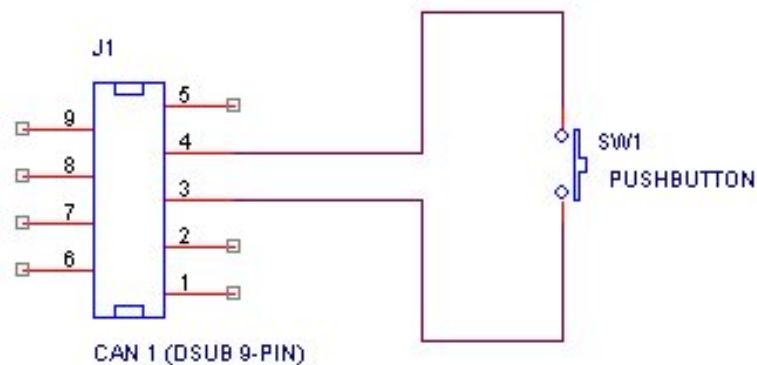

Figure 7: Example of how to connect a button to the External trigger input.

Internally, the External trigger input has a pull-up to +5 V, see Figure 8

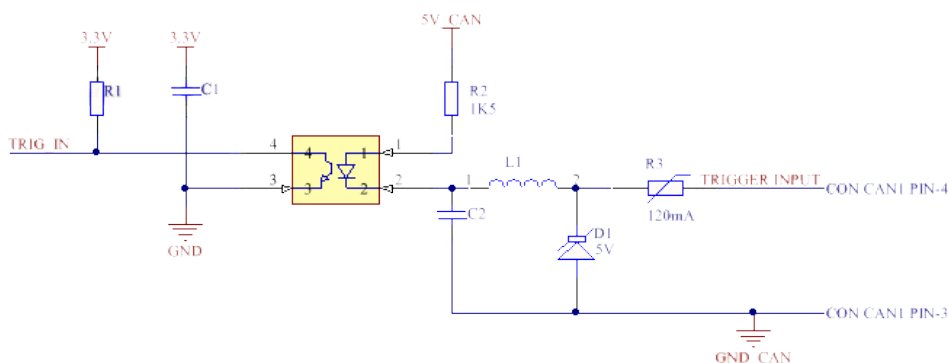

Figure 8: The External trigger input inside the Kvaser Memorator 2xHS v2.

4.6 External trigger output

The Kvaser Memorator 2xHS v2 can be set up to send an external pulse through the External trigger output pin. See Section 4.3, CAN connectors, on Page 16 for pin numbering.

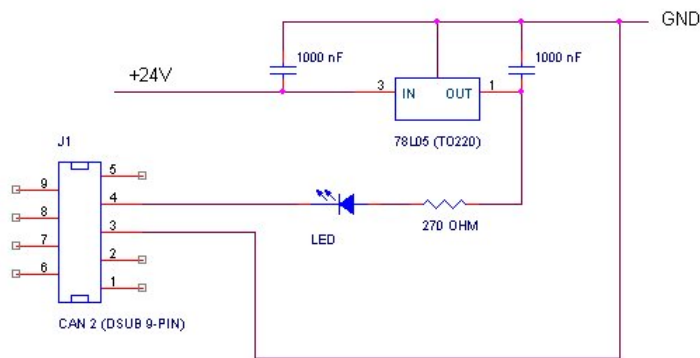

Figure 9: Sample circuit for connecting a LED to the External trigger output.

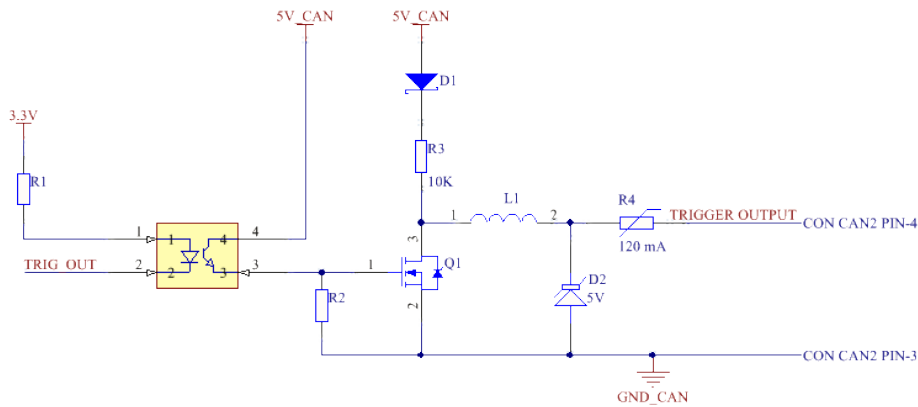

Figure 10: The External trigger output inside the Kvaser Memorator 2xHS v2.

4.7 Daisy Chain Several Devices

You can daisy chain several Kvaser Memorator 2xHS v2 to gain additional logging capacity. To do this, connect the trigger output of one device to the trigger input of the next device. Using the Kvaser Memorator Config Tool, configure the trigger output of the first device to emit a pulse when the disk becomes full. Configure the trigger input of the second device to start logging when a falling edge is detected. Set the post-trigger time to 0 (infinite) and the pre-trigger time to 1 s. You now have a setup where the second unit starts logging when the first one becomes full.

4.8 Updating the firmware

For the Kvaser Memorator 2xHS v2 to communicate with the host computer, compatible versions of the Kvaser CANlib (including driver) and firmware must be installed.

The latest versions of firmware and drivers can be downloaded for free at www.kvaser.com/download.

Connect the Kvaser Memorator 2xHS v2 to your host computer with the USB cable and start the update.exe application. A window opens showing the Firmware Update Instructions; read and follow those carefully.

To check the current firmware version, open "Kvaser Device Guide" which can be found in the Control Panel. Select "Kvaser Memorator 2xHS v2" in the tree view to the left, and click on the channel. The firmware revision information now appears in the right half of the window.

5 Safety Instructions

5.1 Intended Use

Kvaser interfaces are used to connect computer systems to CAN buses. The Kvaser Memorator 2xHS v2 is intended for connection to a computer via the USB port.

5.2 Usage Warning



WARNING FOR ALL USERS

WARNING! - YOUR USE OF THIS DEVICE MUST BE DONE WITH CAUTION AND A FULL UNDERSTANDING OF THE RISKS!

THIS WARNING IS PRESENTED TO INFORM YOU THAT THE OPERATION OF THIS DEVICE MAY BE DANGEROUS. YOUR ACTIONS CAN INFLUENCE THE BEHAVIOR OF A CAN-BASED DISTRIBUTED EMBEDDED SYSTEM, AND DEPENDING ON THE APPLICATION, THE CONSEQUENCES OF YOUR IMPROPER ACTIONS COULD CAUSE SERIOUS OPERATIONAL MALFUNCTION, LOSS OF INFORMATION, DAMAGE TO EQUIPMENT, AND PHYSICAL INJURY TO YOURSELF AND OTHERS. A POTENTIALLY HAZARDOUS OPERATING CONDITION IS PRESENT WHEN THE FOLLOWING TWO CONDITIONS ARE CONCURRENTLY TRUE: THE PRODUCT IS PHYSICALLY INTERCONNECTED TO A REAL DISTRIBUTED EMBEDDED SYSTEM; AND THE FUNCTIONS AND OPERATIONS OF THE REAL DISTRIBUTED EMBEDDED SYSTEM ARE CONTROLLABLE OR INFLUENCED BY THE USE OF THE CAN NETWORK. A POTENTIALLY HAZARDOUS OPERATING CONDITION MAY RESULT FROM THE ACTIVITY OR NON-ACTIVITY OF SOME DISTRIBUTED EMBEDDED SYSTEM FUNCTIONS AND OPERATIONS, WHICH MAY RESULT IN SERIOUS PHYSICAL HARM OR DEATH OR CAUSE DAMAGE TO EQUIPMENT, DEVICES, OR THE SURROUNDING ENVIRONMENT.

WITH THIS DEVICE, YOU MAY POTENTIALLY:

- CAUSE A CHANGE IN THE OPERATION OF THE SYSTEM, MODULE, DEVICE, CIRCUIT, OR OUTPUT.
- TURN ON OR ACTIVATE A MODULE, DEVICE, CIRCUIT, OUTPUT, OR FUNCTION.
- TURN OFF OR DEACTIVATE A MODULE, DEVICE, CIRCUIT, OUTPUT, OR FUNCTION.
- INHIBIT, TURN OFF, OR DEACTIVATE NORMAL OPERATION.
- MODIFY THE BEHAVIOR OF A DISTRIBUTED PRODUCT.
- ACTIVATE AN UNINTENDED OPERATION.
- PLACE THE SYSTEM, MODULE, DEVICE, CIRCUIT, OR OUTPUT INTO AN UNINTENDED MODE.

ONLY THOSE PERSONS WHO:

- (A) ARE PROPERLY TRAINED AND QUALIFIED WITH RESPECT TO THE USE OF THE DEVICE,
- (B) UNDERSTAND THE WARNINGS ABOVE, AND
- (C) UNDERSTAND HOW THIS DEVICE INTERACTS WITH AND IMPACTS THE FUNCTION AND SAFETY OF OTHER PRODUCTS IN A DISTRIBUTED SYSTEM AND THE APPLICATION FOR WHICH THIS DEVICE WILL BE APPLIED, MAY USE THE DEVICE.

PLEASE NOTE THAT YOU CAN INTEGRATE THIS PRODUCT AS A SUBSYSTEM INTO HIGHER-LEVEL SYSTEMS. IN CASE YOU DO SO, KVASER AB HEREBY DECLARES THAT KVASER AB'S WARRANTY SHALL BE LIMITED TO THE CORRECTION OF DEFECTS, AND KVASER AB HEREBY EXPRESSLY DISCLAIMS ANY LIABILITY OVER AND ABOVE THE REFUNDING OF THE PRICE PAID FOR THIS DEVICE, SINCE KVASER AB DOES NOT HAVE ANY INFLUENCE ON THE IMPLEMENTATIONS OF THE HIGHER-LEVEL SYSTEM, WHICH MAY BE DEFECTIVE.

6 Disposal and Recycling Information



When this product reaches its end of life, please dispose of it according to your local environmental laws and guidelines.

Dispose of batteries according to your local environmental laws and guidelines.

For information about Kvaser's recycling programs, visit:
<https://www.kvaser.com/en/kvaser/recycling-policy.html>

7 Legal acknowledgements

7.1 EU Regulatory Compliance



EU Declaration of Conformity (DoC)

We

Company Name:	Kvaser AB	City:	Mölndal
Postal address:	Aminogatan 25	Telephone number:	+46 31 886344
Postcode:	431 53	E-mail address:	sales@kvaser.com

declare that the DoC is issued under our sole responsibility and belongs to the following product:

Product: Kvaser Memorator 2xHS v2

Object of the declaration (identification of apparatus allowing traceability):

Product: Kvaser Memorator 2xHS v2

Type: 73-30130-00821-2

The object of the declaration described above is in conformity with the relevant Union harmonisation legislation:

Electromagnetic Compatibility (EMC) Directive 2014/30/EU (Art. 6)

RoHS recast Directive 2011/65/EU (Art. 4.1)

The following harmonised standards and technical specifications have been applied

(title, date of standard/specification):

EN 55032 (2015 + A11:2020)

EN 55035 (2017 + A11:2020)

EN IEC 63000 (2018)

Signed for and on behalf of:

Mölndal

2025-01-10

Place of issue

Date of issue

Kent Lennartsson, Research Manager

7.2 FCC Regulatory Compliance



Federal Communications Commission (FCC) Compliance Information Statement

IDENTIFICATION OBJECT:

Product: Kvaser Memorator 2xHS v2

Type: 73-30130-00821-2

APPLICABLE COMPLIANCE STATEMENTS:

CFR Title 47 Part 15 §15.107, §15.109

This device complies with part 15 of the FCC Rules.

Operation is subject to the following two conditions:

- (1) This device may not cause harmful interference, and
- (2) this device must accept any interference received, including interference that may cause undesired operation.

RESPONSIBLE PARTY (IN USA) NAME:

Kvaser Inc.

23881 Via Fabricante, Suite 503

Mission Viejo, CA 92691

Internet contact: support@kvaser.com

7.3 Patents, Copyrights and Trademarks

All trademarks are the property of their respective owner. Windows is a registered trademark of Microsoft Corporation in the United States and other countries.

Adobe, the Adobe logo, and Reader are either registered trademarks or trademarks of Adobe Systems Incorporated in the United States and/or other countries.

DeviceNet is a trademark of Open DeviceNet Vendor Association, Inc.

NMEA 2000 is the registered trademark of the National Marine Electronics Association, Inc.

For information about Kvaser related CAN patents, see www.kvaser.com/patent.

8 Document Revision History

Version history for document UG_98173_memo_2hs_v2:

Revision	Date	Changes
1.0	2016-05-02	Initial version.
1.1	2016-06-17	Added charging information under troubleshooting section.
2.0	2017-01-09	Added chapter Daisy Chain, updated compliance text, added link to patents.
3.0	2017-08-25	Updated EU Declaration of Conformity.
3.1	2018-01-29	"Kvaser Device Guide" has replaced "Kvaser Hardware".
3.2	2018-05-07	Minor textual changes.
3.3	2018-08-28	Minor textual changes.
4.0	2018-10-15	Updated EU Regulatory Compliance.
4.1	2019-02-11	Minor textual changes.
4.2	2019-08-09	Url protocol updated.
4.3	2020-01-27	Added sdoc.
4.4	2020-08-19	Updated supported OS.
4.5	2022-04-01	Added Android to Technical data table, minor textual changes.
4.6	2023-02-20	Updated the Technical data table. Added section about intended use. Minor textual changes.
4.7	2024-03-15	Updated Kvaser logo.
4.8	2025-01-10	Updated EU Declaration of Conformity.
4.9	2025-03-24	Updated CAN Transceivers in the Technical data table.
4.10	2025-11-19	Added max sd card size to description.